

58518AA/19AA/20AA/21AA GPS Antenna Cable Kits and GPS Interconnect Cable Kits Information Note

This document describes the Symmetricom 58518AA /19AA /20AA /21AA GPS Antenna Cable Kits and GPS Interconnect Cable Kits.

This document applies to the Symmetricom 58518AA /19AA /20AA /21AA GPS Antenna Cable Kits and GPS Interconnect Cable Kits you have received unless update information is included with the equipment.

For assistance, contact:

Symmetricom, Inc.
2300 Orchard Parkway
San Jose, CA 95131-1017

U.S.A. Call Center:
888-367-7966 (from inside U.S.A. only – toll free)
408-428-7907

U.K. Call Center:
+44.7000.111666 (Technical Assistance)
+44.7000.111888 (Sales)
+44.1604.586740

Fax: 408-428-7998

E-mail: ctac@symmetricom.com

Internet: <http://www.symmetricom.com>

Warning Symbols That May Be Used In This Book



Instruction manual symbol; the product will be marked with this symbol when it is necessary for the user to refer to the instruction manual.



Indicates hazardous voltages.



Indicates earth (ground) terminal.



or



Indicated terminal is connected to chassis when such connection is not apparent.



Indicates Alternating current.



Indicates Direct current.

58518AA / 19AA / 20AA / 21AA

GPS ANTENNA CABLE KITS AND GPS INTERCONNECT CABLE KITS

INFORMATION NOTE

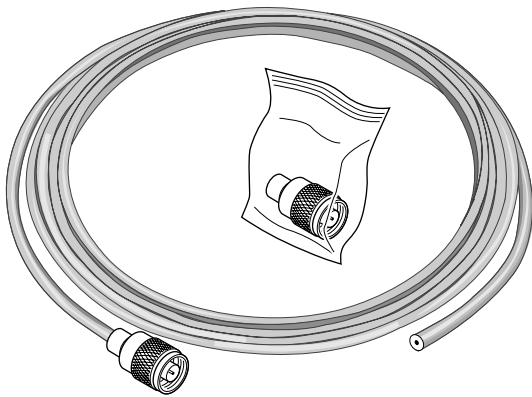

Figure 1. 58518–21AA Cable Kit

1. INTRODUCTION

1.1. The 58518AA / 19AA / 20AA / 21AA antenna cable kits and interconnect cable kits are components in a full line of accessories available from Symmetricom for your GPS system. These accessories have been designed to deliver precise GPS signals over a wide temperature range and harsh environmental conditions.

2. DESCRIPTION

2.1. The 58518 – 21AA series of antenna and interconnect cables are fully insulated and shielded; they are ruggedly constructed for both outdoor and indoor installations. These cables are optimized for low-loss transmission of GPS signals, and are offered in both regular and low-loss types.

2.2. The cable products described within this Information Note are:

- 58518AA GPS Antenna Cable Kit (RG-213)
- 58519AA GPS Interconnect Cable Kit (RG-213)
- 58520AA GPS Antenna Cable Kit (Low-Loss LMR 400)
- 58521AA GPS Interconnect Cable Kit (Low-Loss LMR 400)

2.3. In general, LMR 400 is lower-loss cable allowing longer cable lengths before requiring a line amplifier. There is information at the end of this note about amplifier requirements for long cable runs.

2.4. Available in lengths of 1 – 330 meters (3.3 – 1083 feet), these cables represent an impedance of 50 ohms, with propagation delay per unit length dependent on the cable type (see Table 3).

2.5. The antenna cable kits and interconnect cable kits are each supplied with appropriate connectors, to be installed by the customer. Refer to Table 4 at the end of this note for a listing of cables and their connectors. After installation of the connectors, the interconnect cables can be joined together using N-to-N adapters.

2.6. Symmetricom antenna and interconnect cables are also supplied fully assembled under the series 58518A / 19A / 20A / 21A.

3. INSIDE THIS INFORMATION NOTE

3.1. This note provides information on the following topics:

- Cable description.
- Assembling cables and connectors.
- Installation, including weatherproofing connections and mounting cables.
- Recommended maintenance.
- List of specifications.
- Requirements for line amplifiers.

4. ASSEMBLING CABLES AND CONNECTORS

4.1. This section provides information about assembling cables and connectors.

Table 1. Additional Cable Connectors

Cable Type	Connector Type	Used with Cables	Part Number	Other Part Number
LMR 400	TNC	58520AA	1250-2568	Times Microwave Systems TC-400-TM
LMR 400	N	58520AA/21AA	1250-2570	Times Microwave Systems TC-400-NM
LMR 400	N-90°	58520AA/21AA	1250-2780	
RG-213	TNC	58518AA	1250-2540	AMP 225555-7
RG-213	N	58518AA/19AA	1250-2539	AMP 1-227086-0

Routing and Securing Cables

4.4. In all installations, it will be necessary to comply with national and local building codes when planning your cable runs. Suggestions below are only intended as a guide.

4.5. These GPS Antenna/Interconnect Cables are provided with one end already terminated. The un-terminated end of the cable facilitates pulling through conduit, or other passages, so that connectors are not damaged during this process.

Parts Required

4.2. Having the items listed below on hand will help save time during cable assembly.

- **Included with Cable Kits:**
 - Cable with one of its ends already terminated.
 - Unassembled cable connector.
 - Two pieces of 3M™ EPS300 Heat Shrinkable Environmental Protection Tubing.
- **Customer Supplied:**
 - Additional cable connectors if it is necessary to make unplanned cable cuts. Refer to Table 1 below.

4.3. If additional connectors are needed, refer to the Table 1 for the suggested part numbers.

4.6. The 58518AA and 58520AA cables have one end terminated with a TNC connector. This connector is intended for use with the 58504A GPS Antenna.

4.7. It is recommended that all cable runs use conduit for best protection, wherever possible.

4.8. Do not install cables where they will be submerged in water or exposed to extreme heat or direct flame.

4.9. If connection between cables should be necessary, use an N-to-N adapter.

4.10. Do not install long runs of unsupported cable. The weight of the cable can place undue strain on cable and equipment connectors. Wherever possible, run cables in trays, along walls or beams, supporting them with hangers or clips every meter (3.3 ft).

Tools Required

- Crimping tool, such as the Sargent 4178CT.
- Die: 10.7 mm (.429 in) hex for LMR 400 and RG-213 connectors.
- Saw or cable cutter.
- Knife or other tool to cut insulation.
- Small scissors.
- Soldering iron.
- A heat gun or equivalent heating source to shrink the tubing, if used.

Preparing Cable Ends

4.11. Refer to Figure 2. Flush cut the end of the cable using a fine saw blade. Slide the shrink tubing (if used) (1) and ferrule (crimp ring) (2) over the cut end.

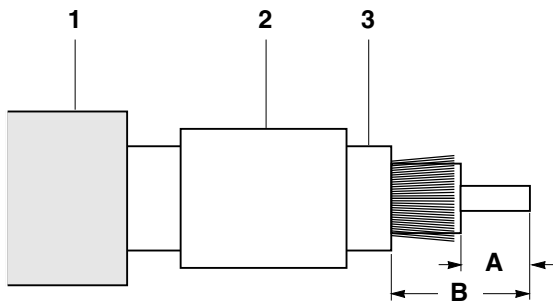

Figure 2. Preparing Cable Ends

4.12. Refer to the procedure below to prepare the cable end for an N or TNC connector. The dimensions for strip gaps are listed in Table 2. The numbers and letters in parentheses refer to Figure 2.

- a. Measure distance (A) back from the flush cut end of the cable.
- b. Cut through the braid and the inner insulation, being careful not to cut into the center conductor.
- c. Measure distance (B) back from the flush cut cable end.
- d. Cut through the outer insulation (3) but not the braided shield.
- e. Using solder, tin center conductor $\frac{3}{4}$ of its length.
- f. Chamfer (de-burr) the end of the center conductor.
- g. Slightly flare out the braid in order that the connector sleeve can more easily slip under the braid.

Table 2. Strip Gap Dimensions

Cable Type	First Cut (A)	Second Cut (B)
LMR 400 TNC	4.4 mm (.175 in)	19 mm (.75 in)
LMR 400 N	5 mm (.2 in)	16 mm (.65 in)
RG-213 TNC or N	4.75 mm (.187 in)	17.45 mm (.687 in)

Attaching cable connectors

4.13. The prepared cable should look like the one shown in Figure 3, step 1.

- a. Solder the contact pin onto the center conductor.
- b. Ensure that the heat shrink tubing (if used) and the ferrule are already fitted onto the cable.
- c. Push the connector body onto the cable by inserting the connector end between the cable's braided ground shield and the insulation covering the inner conductor. (See Figure 3, step 2.)
- d. Slide the ferrule up against the connector body to "crease" the excess braid. Flare out the braids. Slide ferrule back and remove connector body.
- e. Trim excess braid at crease using small scissors.
- f. Install connector body. Slide ferrule up against connector body. (See Figure 3, step 3.)
- g. Crimp ferrule in place with appropriate crimping tool and die. (Refer to "Tools Required," above.) This step completes the connector assembly. (See Figure 3, step 4.)
- h. Next, follow the installation information and weatherproof all cable connections as shown in Figure 4, step 4.

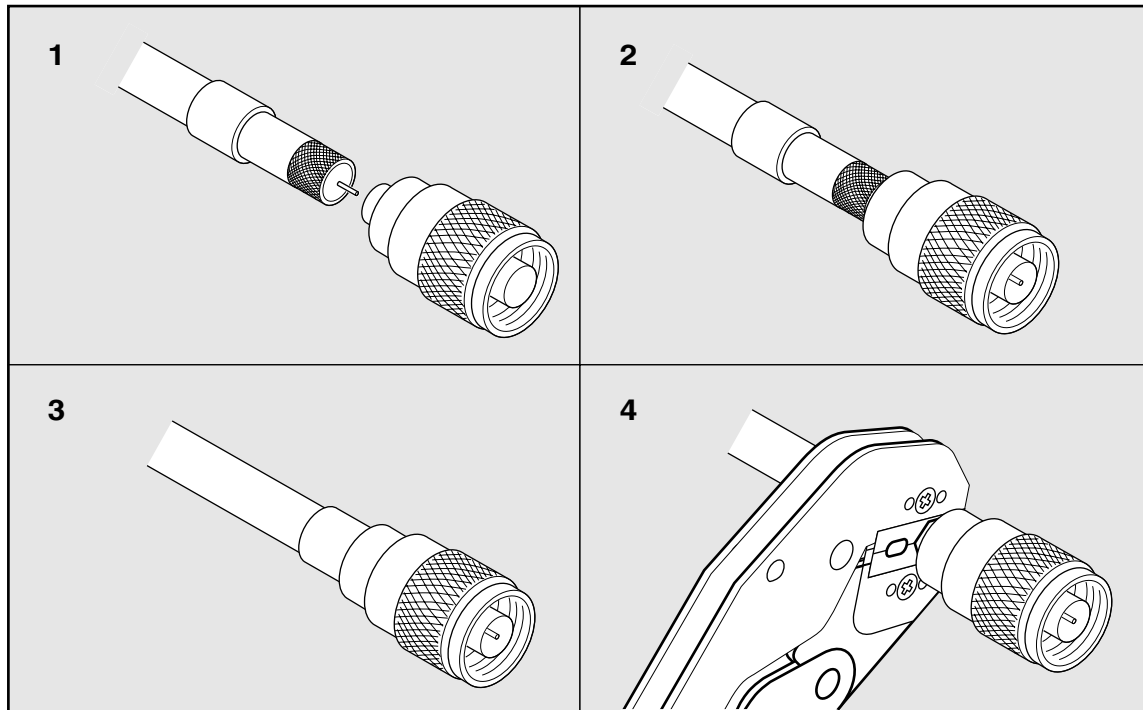

Figure 3. Assembling TNC and N Connectors to Cables

5. INSTALLATION

5.1. This section provides information on weatherproofing the cable connectors.

Parts Required

5.2. Having the items listed below on hand will help save time during installation. When protecting connections from moisture, use heat shrink tubing in locations that require minimum protection. For maximum protection, a multi-barrier process is suggested. This is described below under “Weatherproofing Connections.”

- **Included with Cables:**
 - Two pieces of 3M™ EPS300 Heat Shrinkable Environmental Protection Tubing.
- **Customer Supplied**
 - N (female) to N (female) adapters if you are joining cables together.
 - Additional heat shrink tubing for connections, or other weatherproofing materials as described under “A Multi-Barrier Process” below.
 - Cable hangers, fasteners, clips, or wire trays to support long cable runs.

Tools Required

- A heat gun or equivalent heating source to shrink the tubing.

Weatherproofing Connections/ Environmental Concerns

5.3. All cable connections that are outdoors or exposed to wet or humid environments should be sealed to prevent moisture from entering the connector. Heat shrink tubing may be used, but for maximum protection, use of a multi-barrier process is suggested. Each is described below.

A Multi-Barrier Process

5.4. A multi-barrier process provides the maximum of protection for connections. An example of this process might consist of the following steps:

1. Wrap the connection with a self-fusing, insulating tape (for example, 3M Scotch™ 23 Rubber Splicing Tape).
2. Overwrap the self-fusing, insulating tape with a layer of vinyl electrical tape (for example, 3M Scotch™ Super 88 Vinyl Electrical Tape).
3. Cover the vinyl electrical tape with a layer of oil- and water- resistant coating (for example, 3M Scotchkote™ Electrical Coating).

Note: For specifics, please refer to the manufacturer’s instructions included with each of the products listed above.

Weatherproofing Cable Connections with Heat Shrink Tubing

5.5. A multi-barrier process is suggested for weatherproofing (described above); however, heat shrink tubing, such as 3M™ Heat Shrinkable Environmental Protection Tubing can be used for a minimum level of protection.

5.6. Refer to the steps below and Figure 4 to apply heat shrink tubing. The steps describe connections between two cables or between a cable and a device.

- a. Slip a piece of the supplied shrink tubing over the cable and cable connector. See Figure 4, step 1.
- b. Connect the cable to the N-to-N adapter or to the device connector. See Figure 4, step 2.
- c. Position the heat shrink tubing so that it covers the complete connection, or fits tightly against the case of the device.

Caution: It is critical that you position the shrink tubing next to a device case, and the tubing covers part of the cable(s), and both connectors, before heating. When you heat the tubing, the heat not only shrinks the tubing, but also glues the tubing to the device case, the cable connector, and the cable, to keep out moisture.

- d. Using a heat gun or similar heat source, start heating the shrink tubing at the end nearest the N-to-N adapter or device and work toward the cable as shown in Figure 4, step 3.

Caution: Make sure that you do not overheat devices. Do not point the heat source directly at antenna accessories for an extended period of time.

5.7. Repeat steps a through d for all cable connections. Finished connections should look similar to Figure 4, step 4.

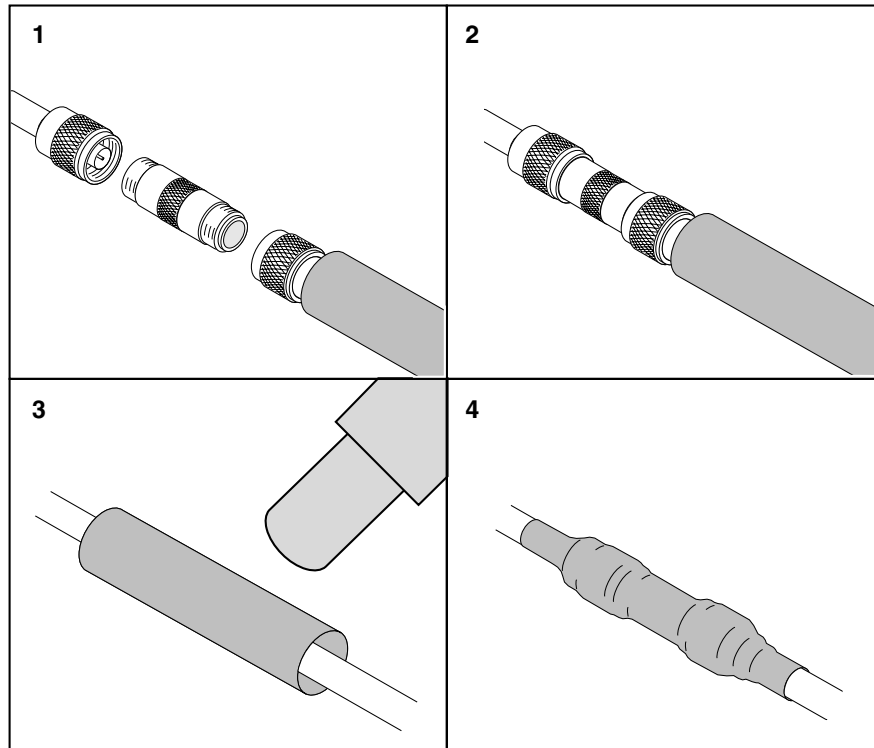

Figure 4. Applying Shrink Tubing

6. MAINTENANCE

6.1. No periodic maintenance is required for the cables. Over time, however, exposure to weather will inevitably cause a deterioration

in the ability of even the protected cable connections to resist moisture and weathering. It is recommended that all components of the antenna system that are exposed to weather be checked periodically and replaced, if it is necessary, as specified in company procedures.

7. SPECIFICATIONS/CHARACTERISTICS

7.1. The following tables present the specifications and characteristics for the 58518AA – 58521AA Antenna and Interconnect Cables.

Table 3. 58518AA– 58521AA Cable Specifications/Characteristics

Electrical Characteristics:	
Impedance	50 Ω
Signal Loss @ 1575.42 MHz (L1)	RG-213 cable (58518AA and 58519AA): 7.9 dB/20 m (12 dB/100 ft) LMR 400 cable (58520AA and 58521AA): 3.35 dB/20 m (5.1 dB/100 ft)
Cable Length Delay (Propagation delay)	RG-213: 5.05 ns/meter (1.54 ns/ft) LMR 400: 3.93 ns/meter (1.2 ns/ft)
Physical Characteristics:	
Diameter	RG-213: 10.29 mm (0.405 in) nominal LMR 400: 10.29 mm (0.405 in) nominal
Minimum Bend Radius	RG-213: 89 mm (3.5 in) LMR 400: 25 mm (1.0 in)
Weight	RG-213: 166 kg/km (111 lbs/1000 ft) LMR 400: 102 kg/km (68 lbs/1000 ft)
Allowable Temperature Range*	RG-213: -20° C to 80° C LMR 400: -40° C to 85° C

* Contact Symmetricom in order to obtain information about other cable vendors for fire-retardant or plenum-rated cables.

Table 4. 58518AA– 58521AA Cable Types and Lengths*

Cable	Type	Grade	Connectors	Available Lengths: Ordered as an option, using desired length as option number.
58518AA	Antenna	RG-213	TNC(m) / N(m)	1, 2, 5, 10, 15, 30, 50 meters
58519AA	Interconnect	RG-213	N(m) / N(m)	1, 2, 5, 10, 15, 30, 50 meters
58520AA	Antenna	LMR 400	TNC(m) / N(m)	1, 2, 5, 10, 15, 30, 60, 110 meters
58521AA	Interconnect	LMR 400	N(m) / N(m)	1, 2, 5, 10, 15, 30, 60, 110, 220, 330 meters

* Contact Symmetricom for purchase of bulk cable.

8. REQUIREMENTS FOR AMPLIFIERS

8.1. This section provides information that will help you decide how many amplifiers you may need for given lengths of cable run.

For LMR 400 cable:

8.2. If cable length between GPS receiver and antenna is:

- Less than 115 meters (377 feet), no line amplifier is necessary.
- More than 115 meters (377 feet) and less than 240 meters (787 feet), you need one line amplifier.
- More than 240 meters (787 feet) and less than 360 meters (1181 feet), you need two line amplifiers.
- More than 360 meters (1181 feet), contact Symmetricom for assistance.

For RG-213 cable:

8.3. If cable length between GPS receiver and antenna is:

- Less than 53 meters (174 feet), no line amplifier is necessary.
- More than 53 meters (174 feet) and less than 105 meters (345 feet), you need one line amplifier.
- More than 105 meters (345 feet) and less than 158 meters (518 feet), you need two line amplifiers.
- More than 158 meters (518 feet), contact Symmetricom for assistance.